



Product information
ELST 4408 RV LH
933 158-001

Name	
ELST 4408 RV LH	
	
Appliance connector for M8 sensors, snap or screw locking, press-in tube mounting, aperture for mini-LED (display window), metal-casing	
Delivery informations	
Availability	no longer available
Product description	
Description	Appliance connector for M8 sensors, snap or screw locking, press-in tube mounting, aperture for mini-LED (display window), metal-casing
Type	ELST 4408 RV LH
Order No.	933 158-001
Type of contact	male
Number of contacts	4
Standard	IEC 61076-2-101 (Ed. 1)/ IEC 60947-5-2
Housing Color	metallic
Technical data	
Pin dimensions	1 mm
Rated voltage	AC/DC 30 V
Rated current	3 A
Type of termination	solder, hollow pins
Suitable cables	max. 0.25 mm ²
Material	
Contact material	Cu Zn
Contact surface material	Au
Contact bearer material	PA transparent
Housing material	Cu ZN/Ni Cr
Environmental conditions	
Protection class (IEC 60529)	IP 67
Pollution severity	3
Temperature range	-25 °C to +90 °C
Inflammability class	
Contact bearer	94 V-2
Approvals	
UL	UL
Packing unit	
Packaging unit	100 pieces

The information published has been compiled as carefully as possible. It is subject to alteration without notice in technical as well as in price related/commercial respect.



Picture
Drawing

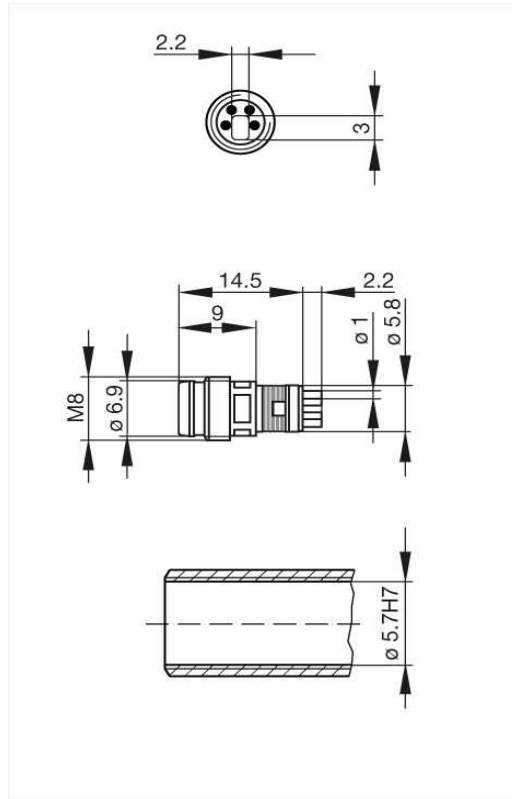

The information published has been compiled as carefully as possible. It is subject to alteration without notice in technical as well as in price related/commercial respect.