

QUINT4-UPS/24DC/24DC/40/PN - Uninterruptible power supply



2907079

<https://www.phoenixcontact.com/gb/products/2907079>

Please be informed that the data shown in this PDF document is generated from our online catalog. Please find the complete data in the user documentation. Our general terms of use for downloads are valid.



QUINT USV, IQ Technology, PROFINET, DIN rail mounting, Screw connection, input: 24 V DC, output: 24 V DC / 40 A, charging current: 5 A

Product description

The intelligent QUINT UPS for integration into established industrial networks: your systems continue to be supplied with uninterrupted power, even in the event of a mains failure. The battery management system with IQ Technology and a powerful battery charger ensures superior system availability.

Your advantages

- Easy integration into networks using PROFINET, EtherNet/IP, EtherCAT® and USB interfaces
- Evaluation of state of health (SOH) and state of charge (SOC), thanks to the intelligent battery management system (BMS)
- Automatic recognition of the battery capacities and technologies (VRLA-WTR, LI-ION)
- Monitoring of output current and voltage, as well as manual connection and disconnection of the system
- SFB Technology selectively trips standard miniature circuit breakers. Loads connected in parallel continue working.

Commercial data

Item number	2907079
Packing unit	1 pc
Minimum order quantity	1 pc
Sales key	CMUI43
Product key	CMUI43
Catalog page	Page 317 (C-4-2019)
GTIN	4055626170039
Weight per piece (including packing)	744 g
Weight per piece (excluding packing)	584 g
Customs tariff number	85371091
Country of origin	CN

QUINT4-UPS/24DC/24DC/40/PN - Uninterruptible power supply



2907079

<https://www.phoenixcontact.com/gb/products/2907079>

Technical data

Input data

Input voltage	24 V DC
Input voltage range	18 V DC ... 30 V DC
	18 V DC ... 32 V DC
Electric strength, max.	35 V DC
Internal input fuse	no
Voltage type of supply voltage	DC
Inrush current	≤ 9 A (≤ 4 ms)
Reverse polarity protection	yes
Fixed backup threshold	22 V DC
Dynamic activation threshold	> 1 V / 100 ms
Switch-on time	max. 3 s
Switch-on time during battery operation (Bat.-Start)	8 s
Voltage drop, input/output	0.5 V DC
Current consumption I_N ($U_N, I_{OUT} = I_N, I_{charge} = 0$)	40.1 A
Current consumption I_{max} ($U_N, I_{OUT} = I_{Stat.Boost}, I_{charge} = max$)	51.2 A
Current consumption $I_{No-Load}$ ($U_N, I_{OUT} = 0, I_{charge} = 0$)	105 mA
Current consumption I_{charge} ($U_N, I_{OUT} = 0, I_{charge} = max$)	6.1 A
Power consumption P_N ($U_N, I_{OUT} = I_N, I_{charge} = 0$)	967 W
Power consumption P_{max} ($U_N, I_{OUT} = I_{Stat.Boost}, I_{charge} = max$)	1122 W
Power consumption $P_{No-Load}$ ($U_N, I_{OUT} = 0, I_{charge} = 0$)	2.6 W
Power consumption P_{charge} ($U_N, I_{OUT} = 0, I_{charge} = max$)	148 W

Output data

Efficiency	typ. 97 %
Number of outputs	1
Nominal output current (I_N)	40 A (-25 °C ... 50 °C)
Short-circuit-proof	yes
No-load proof	yes
Switch-over time	0 ms
Output current limit	In mains mode according to connected upstream current limiting device
	> 45 A (Battery operation)
Power dissipation	2.8 W (Mains operation)
	13 W (Mains operation)
	3.51 W (Battery operation)
	16.4 W (Battery operation)
UPS connection in parallel	no
UPS connection in series	no
Energy storage device connection in parallel	Yes, 5 (observe line protection)

QUINT4-UPS/24DC/24DC/40/PN - Uninterruptible power supply



2907079

<https://www.phoenixcontact.com/gb/products/2907079>

Energy storage device connection in series	no
--	----

Mains operation

Output voltage	24 V DC ($U_{OUT} = U_{IN} - 0.5 \text{ V DC}$)
Output voltage range	18 V DC ... 30 V DC
	18 V DC ... 32 V DC
Output current I_N	40 A
Static Boost ($I_{Stat.Boost}$)	45 A
Dynamic Boost ($I_{Dyn.Boost}$)	60 A (5 s)
Selective Fuse Breaking (I_{SFB})	215 A (15 ms)
Output power P_{OUT} ($U_N, I_{OUT} = I_N$)	960 W
Output power P_{OUT} ($U_N, I_{OUT} = I_{stat.Boost}$)	1080 W

Battery operation

Output voltage	24 V DC ($U_{OUT} = U_{BAT} - 0.5 \text{ V DC}$)
Output voltage range	19 V DC ... 32 V DC
Output current I_N	40 A
Static Boost ($I_{Stat.Boost}$)	45 A
Selective Fuse Breaking (I_{SFB})	215 A (15 ms)
Output power P_{OUT} ($U_N, I_{OUT} = I_N$)	960 W
Output power P_{OUT} ($U_N, I_{OUT} = I_{stat.Boost}$)	1080 W

Energy storage

End-of-charge voltage	32 V DC
End-of-charge voltage (temperature-compensated)	25 V DC ... 32 V DC
Charging current (configurable)	5 A
Nominal capacity (without additional charger)	7 Ah ... 100 Ah
Max. capacity	135 Ah
Charging time	202.5 h
Buffer time	45 min. (38 Ah)
Deep discharge protection	19.2 V DC
Battery technology	VRLA, VRLA-WTR, LI-ION
Charge characteristic curve	IU_0U
IQ-Technology	yes
Temperature sensor	yes
Temperature compensation (configurable)	42 mV/K

Connection data

Input

Position	1.x
----------	-----

Conductor connection

Connection method	Screw connection
rigid	0.5 mm ² ... 16 mm ²

QUINT4-UPS/24DC/24DC/40/PN - Uninterruptible power supply



2907079

<https://www.phoenixcontact.com/gb/products/2907079>

flexible	0.5 mm ² ... 16 mm ²
flexible with ferrule without plastic sleeve	0.5 mm ² ... 16 mm ²
flexible with ferrule with plastic sleeve	0.5 mm ² ... 16 mm ²
rigid (AWG)	8 ... 6 (Cu)
Stripping length	10 mm (rigid/flexible)
Tightening torque	1.2 Nm ... 1.5 Nm
Drive form screw head	Slotted L

Output

Position	2.x
----------	-----

Conductor connection

Connection method	Screw connection
rigid	0.5 mm ² ... 16 mm ²
flexible	0.5 mm ² ... 16 mm ²
flexible with ferrule without plastic sleeve	0.5 mm ² ... 16 mm ²
flexible with ferrule with plastic sleeve	0.5 mm ² ... 16 mm ²
rigid (AWG)	8 ... 6 (Cu)
Stripping length	10 mm (rigid/flexible) 8 mm (Ferrule)
Tightening torque	1.2 Nm ... 1.5 Nm
Drive form screw head	Slotted L

Signal

Position	3.x
----------	-----

Conductor connection

Connection method	Push-in connection
rigid	0.2 mm ² ... 1 mm ²
flexible	0.2 mm ² ... 1 mm ²
flexible with ferrule without plastic sleeve	0.2 mm ² ... 0.75 mm ² 0.5 mm ² (recommended)
flexible with ferrule with plastic sleeve	0.2 mm ² ... 0.75 mm ²
rigid (AWG)	24 ... 16 (Cu)
Stripping length	8 mm (rigid/flexible)

Battery

Position	4.x
----------	-----

Connection technology

Position marking	4.1 (+), 4.2 (-), 4.3 (⏏ 
------------------	--

Conductor connection

Connection method	Screw connection
rigid	0.5 mm ² ... 16 mm ²
flexible	0.5 mm ² ... 16 mm ²

QUINT4-UPS/24DC/24DC/40/PN - Uninterruptible power supply



2907079

<https://www.phoenixcontact.com/gb/products/2907079>

flexible with ferrule without plastic sleeve	0.5 mm ² ... 16 mm ²
flexible with ferrule with plastic sleeve	0.5 mm ² ... 16 mm ²
rigid (AWG)	20 ... 6 (Cu)
Stripping length	10 mm (rigid/flexible)
Tightening torque	1.2 Nm ... 1.5 Nm
Drive form screw head	Slotted L

Interfaces

Interface	PROFINET
Number of interfaces	2
Connection method	RJ45
Supported protocols	PROFINET LLPD
Locking	Locking clip
Transmission physics	Twisted-Pair
Features	Autonegotiation Autocrossing Autopolarity full duplex
Topology	Star Line
Transmission speed	100 Mbps
Transmission length	max. 100 m
Cycle time	1 ms (RT)
Access time	≤ 2 s
Standards	IEEE 802.3 IEC 61158 IEC 61784-2
Chipset	Renesas TPS-1
Electrical isolation	yes
Device ID	0142 _{hex}
Vendor ID	00B0 _{hex}

Signaling

LED signaling

Types of signaling	DC OK (green)
	Alarm (red)
	Bat.-Mode (yellow)
	SOC (red, green)
	Data (red, green)

Product properties

QUINT4-UPS/24DC/24DC/40/PN - Uninterruptible power supply



2907079

<https://www.phoenixcontact.com/gb/products/2907079>

Product type	DC UPS
Product family	QUINT USV
MTBF (IEC 61709, SN 29500)	> 1151000 h (25 °C)
	> 718500 h (40 °C)
	> 365200 h (60 °C)
Environmental protection directive	RoHS Directive 2011/65/EU
	WEEE
	Reach

Insulation characteristics

Protection class	III (without PE)
Degree of pollution	2

Life expectancy (electrolytic capacitors)

Time	126720 h
------	----------

Dimensions

Item dimensions

Width	47 mm
Height	130 mm
Depth	125 mm
	125 mm (Device depth (DIN rail mounting))

Item dimensions with alternative mounting

Width	123 mm
Height	130 mm
Depth	49 mm

Installation dimensions

Installation distance right/left (active)	5 mm / 5 mm ($P_{Out} \geq 50\%$)
Installation distance right/left (passive)	0 mm / 0 mm ($P_{Out} \geq 50\%$)
Installation distance right/left (active, passive)	0 mm / 0 mm ($P_{Out} \leq 50\%$)
Installation distance top/bottom (active)	50 mm / 50 mm ($P_{Out} \geq 50\%$)
Installation distance top/bottom (passive)	40 mm / 20 mm ($P_{Out} \geq 50\%$)
Installation distance top/bottom (active, passive)	40 mm / 20 mm ($P_{Out} \leq 50\%$)

Mounting

Mounting type	DIN rail mounting
Mounting position	On horizontal DIN rail NS 35/7.5 and NS 35/15 acc. to EN 60715

Material specifications

Flammability rating according to UL 94 (housing / terminal blocks)	V0
Housing material	Metal
Hood version	Stainless steel X6Cr17

QUINT4-UPS/24DC/24DC/40/PN - Uninterruptible power supply



2907079

<https://www.phoenixcontact.com/gb/products/2907079>

Side element version	Aluminum AlMg3
----------------------	----------------

Environmental and real-life conditions

Ambient conditions

Degree of protection	IP20
Ambient temperature (operation)	-25 °C ... 70 °C (> 60 °C Derating: 2,5 %/K)
Ambient temperature (storage/transport)	-40 °C ... 85 °C
Ambient temperature (start-up type tested)	-40 °C
Maximum altitude	≤ 4000 m
Climatic class	3K3 (EN 60721)
Max. permissible relative humidity (operation)	≤ 95 % (at 25 °C, non-condensing)
Shock	18 ms, 30g, in each space direction (according to IEC 60068-2-27)
Vibration (operation)	2.3g

Standards and regulations

Protective extra-low voltage

Standard designation	Protective extra-low voltage
Standards/specifications	IEC 61010-1 (SELV)
	IEC 61010-2-201 (PELV)

Approvals

UL approval

Identification	UL/C-UL Listed UL 61010-1
----------------	---------------------------

UL approval

Identification	UL/C-UL Listed UL 61010-2-201
----------------	-------------------------------

UL approval

Identification	UL/C-UL Listed ANSI/ISA-12.12.01 Class I, Division 2, Groups A, B, C, D T4 (Hazardous Location)
----------------	---

CSA

Identification	CAN/CSA-C22.2 No. 61010-1-12
----------------	------------------------------

CSA

Identification	CAN/CSA-IEC 61010-2-201
----------------	-------------------------

CSA

Identification	CAN/CSA-C22.2 No. 213 Class I, Division 2, Groups A, B, C, D T4 (Hazardous Location)
----------------	--

CB scheme

Identification	IEC 61010-1
	IEC 61010-2-201

QUINT4-UPS/24DC/24DC/40/PN - Uninterruptible power supply



2907079

<https://www.phoenixcontact.com/gb/products/2907079>

DNV

Identification	Class Guideline DNVGL-CG-0339
Note	Location classes: Temperature D (see Application/Limitation), Humidity B, Vibration A/C, EMC B

EMC data

Low Voltage Directive	Conformance with Low Voltage Directive 2014/35/EC
EMC requirements for noise emission	EN 61000-6-3
	EN 61000-6-4
EMC requirements for noise immunity	EN 61000-6-1
	EN 61000-6-2
Noise immunity	Immunity in accordance with EN 61000-6-1 (residential), EN 61000-6-2 (industrial), and EN 61000-6-5 (power station equipment zone), IEC/EN 61850-3 (power supply)
Electromagnetic compatibility	Conformance with EMC Directive 2014/30/EU
Noise emission	Additional basic standard EN 61000-6-5 (immunity in power station), IEC/EN 61850-3 (energy supply)

Electrostatic discharge

Standards/regulations	EN 61000-4-2
-----------------------	--------------

Electrostatic discharge

Contact discharge	8 kV (Test Level 4)
Discharge in air	15 kV (Test Level 4)
Comments	Criterion B

Electromagnetic HF field

Standards/regulations	EN 61000-4-3
-----------------------	--------------

Electromagnetic HF field

Frequency range	80 MHz ... 1 GHz
Test field strength	20 V/m (Test Level 3)
Frequency range	1 GHz ... 6 GHz
Test field strength	10 V/m (Test Level 3)
Frequency range	1 GHz ... 6 GHz
Test field strength	10 V/m (Test Level 3)
Comments	Criterion A

Fast transients (burst)

Standards/regulations	EN 61000-4-4
-----------------------	--------------

Fast transients (burst)

Input	4 kV (Test Level 4 - asymmetrical)
Output	4 kV (Test Level 4 - asymmetrical)
Signal	4 kV (Test Level 4 - asymmetrical)
Comments	Criterion B

QUINT4-UPS/24DC/24DC/40/PN - Uninterruptible power supply



2907079

<https://www.phoenixcontact.com/gb/products/2907079>

Surge voltage load (surge)

Standards/regulations	EN 61000-4-5
-----------------------	--------------

Surge voltage load (surge)

Input	1 kV (Test Level 3 - symmetrical)
	2 kV (Test Level 3 - asymmetrical)
Output	1 kV (Test Level 3 - symmetrical)
	2 kV (Test Level 3 - asymmetrical)
Signal	1 kV (Test Level 2 - asymmetrical)
Comments	Criterion B

Conducted interference

Standards/regulations	EN 61000-4-6
-----------------------	--------------

Conducted interference

I/O/S	asymmetrical
Frequency range	0.15 MHz ... 80 MHz
Comments	Criterion A
Voltage	10 V (Test Level 3)

Power frequency magnetic field

Standards/regulations	EN 61000-4-8
Frequency	16.67 Hz
	50 Hz
	60 Hz
Test field strength	100 A/m
Additional text	60 s
Comments	Criterion A
Frequency	50 Hz
	60 Hz
Frequency range	50 Hz ... 60 Hz
Test field strength	1 kA/m
Additional text	3 s
Frequency	0 Hz
Test field strength	300 A/m
Additional text	DC, 60 s

Criteria

Criterion A	Normal operating behavior within the specified limits.
Criterion B	Temporary impairment to operational behavior that is corrected by the device itself.

QUINT4-UPS/24DC/24DC/40/PN - Uninterruptible power supply



2907079

<https://www.phoenixcontact.com/gb/products/2907079>

Drawings

Block diagram

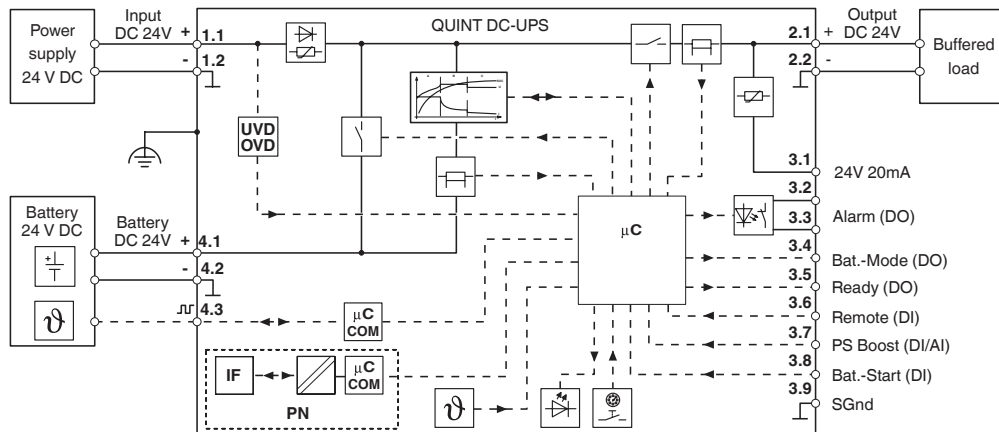

Block diagram

QUINT4-UPS/24DC/24DC/40/PN - Uninterruptible power supply



2907079

<https://www.phoenixcontact.com/gb/products/2907079>

Approvals

To download certificates, visit the product detail page: <https://www.phoenixcontact.com/gb/products/2907079>



EAC

Approval ID: RU S-DE.BL08.W.00764



UL Listed

Approval ID: FILE E 123528



cUL Listed

Approval ID: FILE E 123528

PROFINET

Approval ID: Z12096



EAC

Approval ID: RU-DE.B.00184/20

DNV

Approval ID: TAA00002K4



KC

Approval ID: R-R-PCK-2907079



LR

Approval ID: LR21417906TA

ClassNK

NK

Approval ID: TA22372M



BV

Approval ID: 69394/A0 BV



RINA

Approval ID: ELE382621XG

QUINT4-UPS/24DC/24DC/40/PN - Uninterruptible power supply



2907079

<https://www.phoenixcontact.com/gb/products/2907079>

ABS

Approval ID: 21-2174010-PDA



cUL Listed

Approval ID: FILE E 199827



UL Listed

Approval ID: FILE E 199827

cULus Listed

cULus Listed

QUINT4-UPS/24DC/24DC/40/PN - Uninterruptible power supply



2907079

<https://www.phoenixcontact.com/gb/products/2907079>

Classifications

ECLASS

ECLASS-11.0	27040705
ECLASS-13.0	27040705
ECLASS-12.0	27040705
ECLASS-14.0 ASSET	27250101

ETIM

ETIM 9.0	EC000382
----------	----------

UNSPSC

UNSPSC 21.0	39121000
-------------	----------

QUINT4-UPS/24DC/24DC/40/PN - Uninterruptible power supply



2907079

<https://www.phoenixcontact.com/gb/products/2907079>

Environmental product compliance

EU RoHS

Fulfills EU RoHS substance requirements	Yes
Exemption	7(a), 7(c)-I

China RoHS

Environment friendly use period (EFUP)	EFUP-25
	An article-related China RoHS declaration table can be found in the download area for the respective article under "Manufacturer declaration". For all articles with EFUP-E, no China RoHS declaration table issued and required.

EU REACH SVHC

REACH candidate substance (CAS No.)	Lead(CAS: 7439-92-1)
-------------------------------------	----------------------

QUINT4-UPS/24DC/24DC/40/PN - Uninterruptible power supply



2907079

<https://www.phoenixcontact.com/gb/products/2907079>

Accessories

UPS-BAT/PB/24DC/7AH - Battery module

1274118

<https://www.phoenixcontact.com/gb/products/1274118>



Battery module, VRLA-AGM, 24 V DC, 7 Ah, automatic detection and communication with QUINT UPS-IQ

UPS-BAT/PB/24DC/12AH - Battery module

1274119

<https://www.phoenixcontact.com/gb/products/1274119>



Battery module, VRLA-AGM, 24 V DC, 12 Ah, automatic detection and communication with QUINT UPS-IQ

QUINT4-UPS/24DC/24DC/40/PN - Uninterruptible power supply



2907079

<https://www.phoenixcontact.com/gb/products/2907079>

UPS-BAT/PB/24DC/20AH - Battery module

1348516

<https://www.phoenixcontact.com/gb/products/1348516>



Battery module, VRLA-AGM, 24 V DC, 20 Ah, automatic detection and communication with QUINT UPS-IQ

UPS-BAT/PB/24DC/40AH - Battery module

1354641

<https://www.phoenixcontact.com/gb/products/1354641>



Battery module, VRLA-AGM, 24 V DC, 40 Ah, automatic detection and communication with QUINT UPS-IQ

QUINT4-UPS/24DC/24DC/40/PN - Uninterruptible power supply



2907079

<https://www.phoenixcontact.com/gb/products/2907079>

UPS-BAT/LI/24DC/128WH - Battery module

1396415

<https://www.phoenixcontact.com/gb/products/1396415>



Battery module, Lithium-Ion (LiFePO₄), 24 V DC, 128 Wh. For use with a QUINT UPS for ambient temperatures (charging) of 0°C ... 60°C and a maximum charging current of 5 A. For charging below 0°C, please note the permissible UPS V/C level.

UPS-BAT/VRLA-WTR/24DC/13AH - Battery module

2320416

<https://www.phoenixcontact.com/gb/products/2320416>



Battery module, lead AGM, VRLA technology, 24 V DC, 13 Ah, tool-free battery replacement, automatic detection, and communication with QUINT UPS-IQ

QUINT4-UPS/24DC/24DC/40/PN - Uninterruptible power supply



2907079

<https://www.phoenixcontact.com/gb/products/2907079>

UPS-BAT/VRLA-WTR/24DC/26AH - Battery module

2320429

<https://www.phoenixcontact.com/gb/products/2320429>

Battery module, lead AGM, VRLA technology, 24 V DC, 26 Ah, tool-free battery replacement, automatic detection, and communication with QUINT UPS-IQ



Phoenix Contact 2024 © - all rights reserved
<https://www.phoenixcontact.com>

PHOENIX CONTACT Ltd
Halesfield 13, Telford
Shropshire, TF7 4PG
01952 681700
info@phoenixcontact.co.uk